

UNITED STATES PATENT AND TRADEMARK OFFICE

BEFORE THE OFFICE OF THE UNDER SECRETARY OF COMMERCE
FOR INTELLECTUAL PROPERTY AND DIRECTOR OF THE
UNITED STATES PATENT AND TRADEMARK OFFICE

PLR WORLDWIDE SALES LTD.,
Petitioner,

v.

FLIP PHONE GAMES INC.,
Patent Owner.

IPR2024-00133
Patent 8,688,089 B2

Before KATHERINE K. VIDAL, *Under Secretary of Commerce for
Intellectual Property and Director of the United States Patent and
Trademark Office.*

DECISION

Granting Director Review, Vacating the Decision Denying Institution, and
Remanding to the Patent Trial and Appeal Board
for Further Proceedings

I. INTRODUCTION

On November 7, 2023, PLR Worldwide Sales Ltd. (“Petitioner”) filed a Petition requesting an *inter partes* review of claims 1–10 of U.S. Patent No. 8,688,089 B2 (Ex. 1001, “the ’089 patent”). Paper 2 (“Pet.”). Flip Phone Games Inc. (“Patent Owner”) filed a Preliminary Response (Paper 7, “Prelim. Resp.”). With Board authorization, Petitioner filed a Preliminary Reply (Paper 8, “Prelim. Reply”), and Patent Owner filed a Preliminary Sur-reply (Paper 9, “Prelim. Sur-reply”). On April 29, 2024, in a split decision, the Board majority denied institution of *inter partes* review. Paper 10, 1–30 (“Dec.”).¹

The Board majority determined that Petitioner did not demonstrate a reasonable likelihood that Petitioner would prevail in establishing the unpatentability of any of the challenged claims of the ’089 patent. Dec. 30. The dissent disagreed with the Board majority’s claim construction of the term “a non-promotional background object,” and would have instituted trial. Paper 10, 1–7 (“Dissent”). On May 29, 2024, Petitioner filed a request for Director Review of the Board’s Decision denying institution. Paper 11 (“DR Request”). Petitioner argues, in part, that the Board majority’s construction of “background” improperly relies on the subjective understanding of a user. DR Request 1, 7–8, 12–13.

I have reviewed Petitioner’s Request, the Board’s Decision denying institution, and the Papers and Exhibits of record in this proceeding. I determine that Director Review of the Board’s Decision denying institution

¹ The Decision denying institution includes both a majority opinion labeled pages 1–30 and a dissenting opinion labeled pages 1–14.

is appropriate. *See Revised Interim Director Review Process*² §§ 4.B, 5.A. For the reasons discussed in further detail below, I respectfully vacate the Board’s Decision denying institution and remand for further proceedings consistent with this decision.

II. BACKGROUND

The ’089 patent discloses “[s]ystems and methods for providing hot spots for mobile video games on mobile communication devices that receive hot spot information for mobile video games that operate on the devices.” Ex. 1001, Abstract.

Figure 2A of the ’089 patent, reproduced below, is “an exemplary scene in a video game played on a mobile communication device.” *Id.* at 3:43–45.

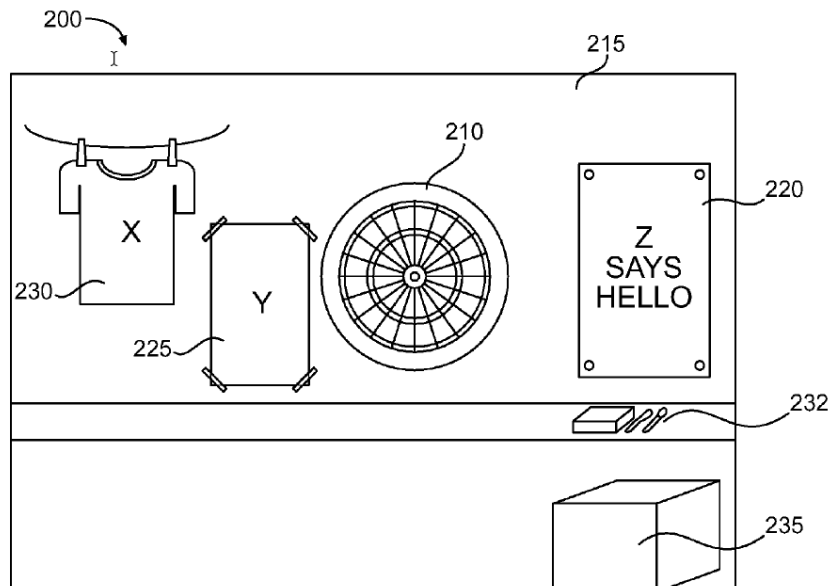

FIG. 2A

² Available at www.uspto.gov/patents/ptab/decisions/revised-interim-director-review-process.

Scene 200 depicted in Figure 2A depicts a darts game including dart board 210 and items 220, 225, 230, and 235. *Id.* at 6:38–40, 6:44–54. In this example, any of items 210, 220, 225, 230, and 235 may be hot spots. *Id.* “A hot spot can be thought of as a location or item, sometimes hidden within the game, that triggers additional specialized content when activated by a user or some other in-game element.” *Id.* at 1:63–66. For example, the ’089 patent states that “if the user throws a dart that hits shirt 230, a promotional message associated with third party X may pop up on screen.” *Id.* at 6:47–49. According to the ’089 patent, “[p]romotional messages might also be displayed if the user activates hot spots on poster 225 or chalk board 220.” *Id.* at 6:51–52. Further, if the user activates a hot spot represented by chalk 232, a new message may appear on chalk board 220. *Id.* at 6:53–54.

Independent claim 1 of the ’089 patent recites, in pertinent part, “hot spot information comprising: a location in-game associated with activating the hot spot, wherein the location in-game is represented by a *non-promotional background object*.” Ex. 1001, 14:25–29 (emphasis added). The specification does not define or even use the phrase “non-promotional background object” or “background object.”

Neither party expressly requested a construction of the claim term “non-promotional background object.” *See* Pet. 13; Prelim. Resp. 21–25. However, in its analysis of the prior art, Petitioner relied on the patent applicant’s statements, made during prosecution, that “‘non-promotional background objects’ are not game components, i.e., ‘featured objects that a user manipulates in order to play the game,’ but are rather ‘outside of the

primary focus of game play’ and ‘are not themselves needed or required in order to play the game.’” Pet. 31 (quoting Ex. 1002, 85).

Patent Owner similarly relied on statements made during prosecution to assert that “‘non-promotional background objects’ are not game components, but instead they exist in the background, outside of the primary focus of game play and as unexpectedly interactive components, and are not themselves needed or required in order to play the game.” Prelim. Resp. 32 (quoting Ex. 1002, 85). Patent Owner further asserted that a “non-promotional object is not an ordinary or visible place for advertisement.” *Id.* at 36 (quoting Ex. 1002, 122).

In this proceeding, Petitioner proposed three grounds of unpatentability challenging claims 1–10 of the ’089 patent, all of which involve Ho³ and one of which involves Sturman,⁴ among other references.⁵ Pet. 17–64.

Petitioner relied on Ho’s interactive information elements to disclose the claimed non-promotional background object, arguing that they “do not display promotional content until a user has perform a predetermined action.” *Id.* at 31–32 (citing Ex. 1004, 2:11–12). Petitioner also argued that “engagement of [Ho’s] at least one interactive information element may not be mandatory for the continuation of gameplay.” *Id.* (citing Ex. 1004, 4:26–28, 5:30–33, 5:36–38).

³ WO 2008/008038 A1, published January 17, 2008, filed designating the United States July 12, 2006 (Ex. 1004).

⁴ WO 2006/071246 A1, published July 6, 2006 (Ex. 1006).

⁵ Because my decision below does not turn on any details associated with either Ho or Sturman, a detailed explanation of these references is not necessary.

Petitioner further relied on Sturman’s “ad units” as non-promotional background objects because “the advertisement server ‘may be used to track and manage large sets of available ad units from multiple game titles,’” where the ad units “may include non-promotional in-game background elements, such as storefront signs, Jumbotron screens, posters, and t-shirts on characters.” *Id.* at 56–57 (citing Ex. 1006 ¶¶ 19, 22; Ex. 1003 ¶ 176).

III. ANALYSIS

In the Decision denying institution, the Board majority did not expressly construe any claim term, but addressed “the parties’ implicit claim constructions” in its merits analysis. Dec. 10. With respect to the “background” element, the Board first determined that “‘background’ objects are not primary objects.” *Id.* at 20. The Board explained that “in terms of a mobile video game, such as the one claimed in the ’089 patent, ‘background’ refers to objects other than primary game objects.” *Id.* The Board then agreed with Patent Owner that Ho’s interactive elements are not “background objects” because “nothing in the cited paragraphs indicates that those interactive information elements are ‘outside the primary focus of game play and as unexpectedly interactive components.’” *Id.* at 22 (citing Pet. 31–21); *see* Ex. 1002, 85.

With respect to the “non-promotional” element, the Board determined that Petitioner’s assertion that Sturman’s ad units are non-promotional was conclusory. *Id.* at 29 (citing Pet. 57). The Board explained that Sturman did not describe its ad units as non-promotional objects and that Sturman “identifies a number of objects that a person having ordinary skill in the art

would understand are or could be promotional objects such as billboard or storefront signs.” *Id.*

Having considered the Decision denying institution, for the reasons discussed below, I agree with Petitioner that the Board’s claim construction of the term “a non-promotional background object” was improperly based on the subjective views of the user. DR Request 12–13 (citing *Amazon.com, Inc. v. Barnesandnoble.com, Inc.*, 239 F.3d 1343, 1353 (Fed. Cir. 2001) (“We are not prepared to assign a meaning to a patent claim that depends on the state of mind of the accused infringer.”)); Dec. 20–23, 29.

With respect to the “background” element, the Board majority’s analysis turns on whether an element is “outside the primary focus of game play and [] unexpectedly interactive.” *Id.* (emphasis added). I agree with the dissent that the Board majority’s consideration here of what a user would expect (“unexpectedly interactive”) was improperly based on the subjective perspective of a user. Dissent 7–9.

Therefore, I respectfully vacate the Board’s Decision denying institution and remand to the Board for further proceedings. The Board shall issue a new decision on institution resolving the claim construction of “a non-promotional background object.” Consistent with *Phillips v. AWH Corp.*, 415 F.3d 1303, 1313–14 (Fed. Cir. 2005), the Board should resolve the proper meaning of that term by first assessing the intrinsic evidence, and then consulting extrinsic evidence if necessary. *See, e.g., Samsung Elecs. Co., Ltd. v. Slyde Analytics, LLC*, IPR2024-00040, Paper 14 at 7–8 (Vidal Aug. 2, 2024) (discussing the *Phillips* framework). The Board shall

consider all remaining necessary issues,⁶ and determine whether to institute trial consistent with this decision.

IV. ORDER

In consideration of the foregoing, it is hereby:

ORDERED that Director Review is granted;

FURTHER ORDERED that the Board's Decision denying institution (Paper 10) is vacated; and

FURTHER ORDERED that the captioned proceeding is remanded to the Board for further proceedings consistent with this decision.

⁶ I reject Patent Owner's argument that the Ho reference (Ex. 1004) is not "prior art consisting of patents or printed publications" under 35 U.S.C. § 311(b). *See* Prelim. Reply 42–45. Although the issue is currently on appeal before the Federal Circuit (in *Lynk Labs, Inc. v. Samsung Electronics Co.*, Appeal No. 23-2346), the USPTO's position and practice is that petitioners may rely on 35 U.S.C § 102(e)(1) art.

IPR2024-00133
Patent 8,688,089 B2

FOR PETITIONER:

James Glass
Quincy Lu
Nima Hefazi
QUINN EMANUEL URQUHART & SULLIVAN, LLP
jimglass@quinnemanuel.com
quincylu@quinnemanuel.com
nimahefazi@quinnemanuel.com

FOR PATENT OWNER:

Michael Morlock
Joshua Lee
Andrew Rinehart,
Kasey Koballa
KILPATRICK TOWNSEND & STOCKTON LLP
mmorlock@kilpatricktownsend.com
jlee@kilpatricktownsend.com
arinehart@kilpatricktownsend.com
kkoballa@kilpatricktownsend.com